

# Introducing the ProView

Designed for Refuse

- Low Entry
- High Visibility
- Made in America

 **DENNIS EAGLE**  
A TERBERG ROSROCA COMPANY



> TO LEARN MORE VISIT US ONLINE AT [RUSHTRUCKCENTERS.COM/DENNISEAGLE](https://RUSHTRUCKCENTERS.COM/DENNISEAGLE) | TO INQUIRE ABOUT A TRUCK CONTACT US AT 855-765-7874.

# Earning its stars and stripes

Advanced features to rise above the rest.



## ★ Unbeatable visibility

The low, 'eye-level' driving position ensures the driver makes direct eye contact with other road users. This enables a clearer understanding between them so they know each other's intentions which improves safety. The lower driving position, coupled with the panoramic view, means the ProView provides unrivalled direct vision of other road users and obstacles.

## ★ All-round comfort

The spacious ProView is designed for comfort and safety. The flat, unobstructed walk-thru floor makes it easy to move from door to door. Multiple seating configurations meet any operational needs. Ergonomically placed controls, a digital dash display and a telescopic, tilting steering wheel make it a joy to drive. And with noise levels below 70db you don't have to shout to be heard.

## ★ Built to outlast

Made from stainless steel, the tough, rust-resistant cab frame is treated to a four-stage paint process to withstand the harshest environments. The ProView is approved to the FMVSS crash standard. Disc and anti-lock brakes give superb stopping power and the powerful, efficient Cummins L9 or L9N engines offer high torque at low speeds – just as refuse collection demands.

## ★ Easy and safe entry and exit

We know how important it is for your drivers and crews to avoid accidents at work, so the ProView is designed with them in mind. Getting in and out of the cab on both sides is easy, thanks to its single, low, anti-slip step and the totally flat, unobstructed floor. This provides anyone in the cab with the option of safely stepping out onto the kerb rather than into traffic.

# Designed better to perform better



## Made in the USA, proven around the world

Designed specifically for waste collection, Dennis Eagle's ProView cab delivers the ultimate in safety, ergonomics and strength. Our low entry cab gives drivers the best vision of any truck on the road. It also provides unrivalled performance and has already been proven in the toughest climates in the world. The American-made ProView is built in Summerville, SC, by Dennis Eagle, the world leader in the design and manufacture of refuse vehicles and part of the Terberg RosRoca Group.

## Safety from every angle

We care about the communities our vehicles operate in and their safety is paramount. Our original design brief was for the driver to be able to see a 1.0m tall child standing 1.0m in front of the truck. We achieved that with a rear-mounted engine and large, panoramic windows that offer a greater field of view than any other cab. In addition, bigger side windows and rear-view mirrors keep crew, cyclists and pedestrians all in plain sight.

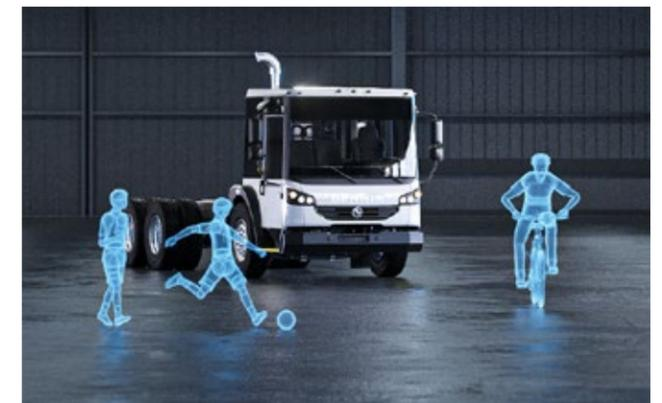

# Made of tougher stuff

## Chassis engineered for refuse collection

The chassis is robust, designed for refuse collection and is compatible with a wide range of bodies. With no sub frame required, it stands strong, providing firm traction and protects the body mount from punishing roads. The Dana axles are designed for special trucks that require outstanding maneuverability.



### ★ Responsive braking and smoother suspension

Big trucks demand great brakes and on the ProView, air, disc and antilock brakes come as standard, so you know you'll have the stopping power when you need it. The rubber drive suspension, with VariRate Spring System and telescopic shock absorbers, provides the best balance between loaded and unloaded ride quality and stability, while reducing weight.



### ★ The power to deliver

Powered by the Cummins L9 or L9N engine and Allison transmission, the ProView offers plenty of muscle, with high torque at low speeds across a wide RPM spectrum. This creates a better output and potential fuel savings. It also offers an exceptional power-to-weight ratio, durability and the uptime you expect from such a proven drivetrain.

# Custom-designed for **bodybuilders**

Based on Dennis Eagle's in-depth knowledge of refuse collection operations around the world, the ProView has been tailor-made for the North American market. We're used to working closely with bodybuilders and totally understand their needs. We are fully familiar with their interface requirements and have worked with many of the top bodybuilders in North America. And our network of established dealers provides access to proven solutions and covers all the bases for stock and spares across the whole of North America.

## ★ Fully compatible electrics

The ProView is equipped with a new 12v electrical system that has been developed for the North American market. It is fully compatible with both RP170 and J1319 standards, making the vehicle easy to integrate with the rest of your fleet.



# Higher spec as standard

The ProView comes with a host of premium specifications fitted as standard to improve comfort and the overall driving experience. Items, such as a digital dash and electric windows, heated mirrors, passenger footrests and block heaters, have been fitted to keep drivers and crews both happy and productive.

## Wheel plans

- 6x4
- 8x4 Tag
- Range of wheelbases



## Drive configurations

- Dual steer
- Left hand drive + 3 crew

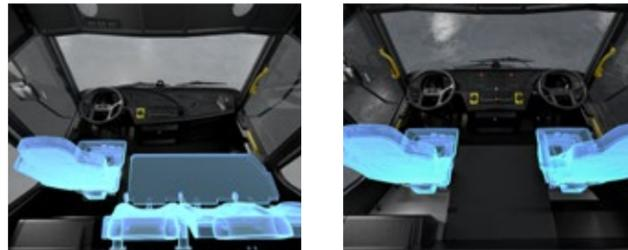

## Premium spec as standard, including:

- Electric windows
- Heated mirrors
- Sun visors
- Heated, air-suspended driver's seat
- Mechanically operated hydraulic cab tilt
- Flat roof with compliant marker lights
- Interior lighting with adjustable beam function
- Coat pegs behind seats
- Cruise control
- 3 rear windows
- Driver armrest
- Air conditioning



## ProView 8x4 Tag - Dual Control/LHS

CNG

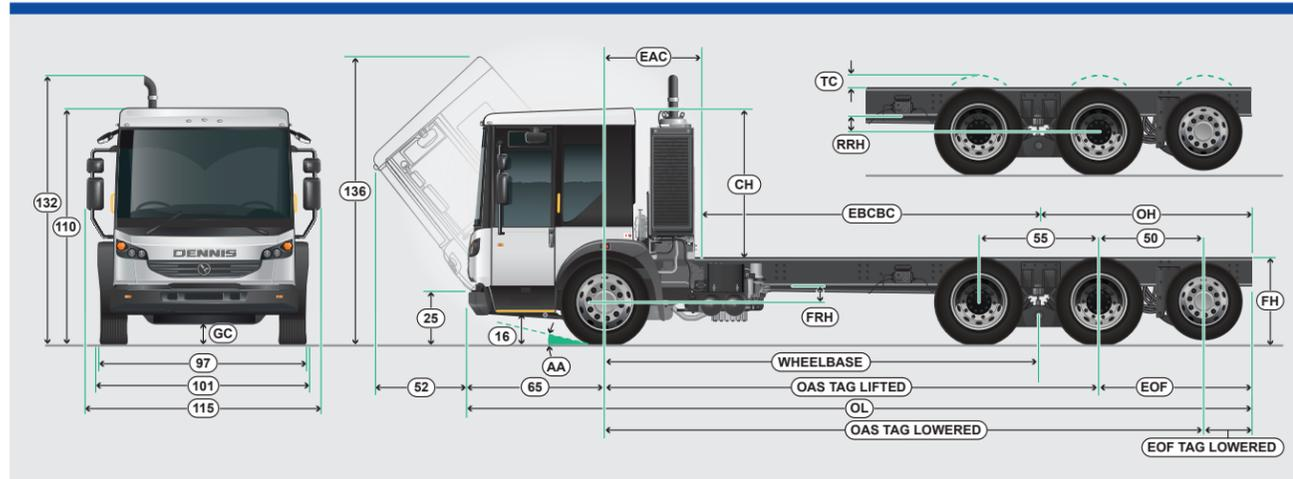

### Seating position options



### Wheel Plan

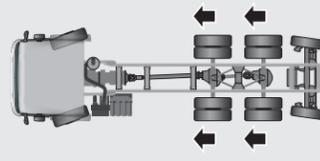

Wheelbase		205" + TAG	230" + TAG
OAS TAG LIFTED	Outer axle spread	232"	257"
OAS TAG LOWERED		282"	307"
OL	Overall length	371"	396"
EAC	Effective axle 1 to back of cab	43"	43"
EBBC	Effective bumper to back of cab	108"	108"
EBCBC	Effective back of cab to bogie centre	162"	187"
OH	Frame overhang from bogie centre	101"	101"
EOF	End of frame from rear drive axle	74"	74"
EOF TAG LOWERED		24"	24"
AA	Approach angle	14.5 degrees	14.5 degrees
GC	Ground clearance - Tag axle raised	9"	9"
	Ground clearance - Tag axle lowered	7.1"	7.1"
FH	Chassis frame height	42"	42"
TC	Tire clearance (minimum)	10"	10"
CH	Cab height from frame	69.5"	69.5"
FRH	Front ride height	7"	7"
RRH	Rear ride height	7"	7"
TC W-W	Turning circle (wall to wall), tag axle lifted, ft #	72.8'	78.7'
TC C-C	Turning circle (curb to curb), tag axle lifted, ft ##	66.7'	72.7'
GVWR	Maximum plated vehicle weight	61700 lbs	61700 lbs
	Steer axle maximum weight	20000 lbs	20000 lbs
	Drive axles maximum weight	44000 lbs	44000 lbs
	Tag axle maximum weight	11000 lbs	11000 lbs
	Unladen vehicle weight <sup>§</sup>	20202 lbs	20400 lbs
	Front axle unladen weight	10370 lbs	10468 lbs
	Rear axles unladen weight	9832 lbs	9932 lbs

# Dimension shown is for steer wheels, add approximately 2.5" for alloy wheels.

## Dimension shown is for steer wheels, add approximately 2.65" for alloy wheels.

§ Alloy wheels reduce unladen weight by 695 lbs (front axle by 68 lbs, rear axles by 627 lbs).

## ProView 8x4 Tag - Dual Control/LHS

DIESEL

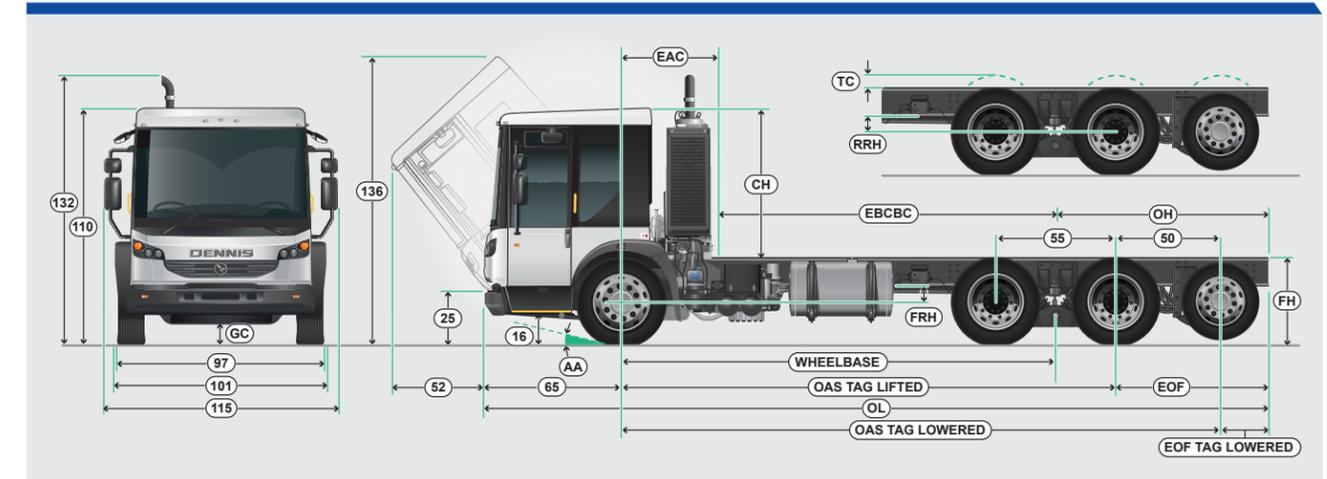

### Seating position options



### Wheel Plan

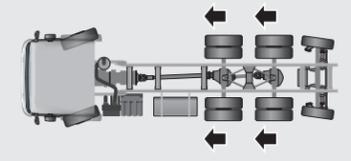

Wheelbase		205" + TAG	230" + TAG
OAS TAG LIFTED	Outer axle spread	232"	257"
OAS TAG LOWERED		282"	307"
OL	Overall length	371"	396"
EAC	Effective axle 1 to back of cab	43"	43"
EBBC	Effective bumper to back of cab	108"	108"
EBCBC	Effective back of cab to bogie centre	162"	187"
OH	Frame overhang from bogie centre	101"	101"
EOF	End of frame from rear drive axle	74"	74"
EOF TAG LOWERED		24"	24"
AA	Approach angle	14.5 degrees	14.5 degrees
GC	Ground clearance - Tag axle raised	9"	9"
	Ground clearance - Tag axle lowered	7.1"	7.1"
FH	Chassis frame height	42"	42"
TC	Tire clearance (minimum)	10"	10"
CH	Cab height from frame	69.5"	69.5"
FRH	Front ride height	7"	7"
RRH	Rear ride height	7"	7"
TC W-W	Turning circle (wall to wall), tag axle lifted, ft #	72.8'	78.7'
TC C-C	Turning circle (curb to curb), tag axle lifted, ft ##	66.7'	72.7'
GVWR	Maximum plated vehicle weight	61700 lbs	61700 lbs
	Steer axle maximum weight	20000 lbs	20000 lbs
	Drive axles maximum weight	44000 lbs	44000 lbs
	Tag axle maximum weight	11000 lbs	11000 lbs
	Unladen vehicle weight <sup>§</sup>	20802 lbs	21000 lbs
	Front axle unladen weight	10671 lbs	10768 lbs
	Rear axles unladen weight	10131 lbs	10232 lbs

# Dimension shown is for steer wheels, add approximately 2.5" for alloy wheels.

## Dimension shown is for steer wheels, add approximately 2.65" for alloy wheels.

§ Alloy wheels reduce unladen weight by 695 lbs (front axle by 68 lbs, rear axles by 627 lbs).

## ProView 6x4 - Dual Control/LHS

CNG

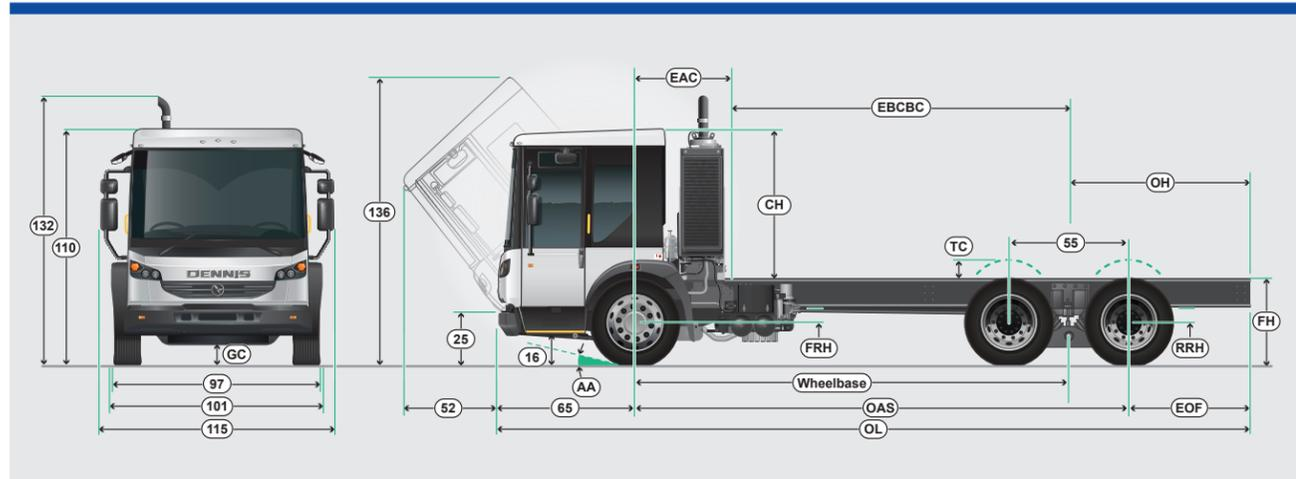

### Seating position options



### Wheel Plan

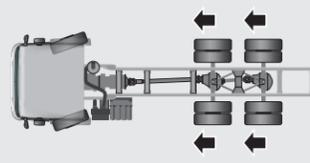

Wheelbase		181"	193"	205"	230"
OAS	Outer axle spread	208"	220"	232"	257"
OL	Overall length	333"	345"	357"	382"
EAC	Effective axle 1 to back of cab	43"	43"	43"	43"
EBBC	Effective bumper to back of cab	108"	108"	108"	108"
EBCBC	Effective back of cab to bogie centre	138"	150"	162"	187"
OH	Frame overhang from bogie centre	86"	86"	86"	86"
EOF	End of frame from rear axle	59"	59"	59"	59"
AA	Approach angle	14.5 degrees	14.5 degrees	14.5 degrees	14.5 degrees
GC	Ground clearance	9"	9"	9"	9"
FH	Chassis frame height	42"	42"	42"	42"
TC	Tire clearance (minimum)	10"	10"	10"	10"
CH	Cab height from frame	69.5"	69.5"	69.5"	69.5"
FRH	Front ride height	7"	7"	7"	7"
RRH	Rear ride height	7"	7"	7"	7"
TC W-W	Turning circle (wall to wall), ft #	64.7'	68.2'	72.8'	78.7'
TC C-C	Turning circle (curb to curb), ft ##	58.7'	62.1'	66.7'	72.7'
GVWR	Maximum plated vehicle weight	61700 lbs	61700 lbs	61700 lbs	61700 lbs
	Front axle maximum weight	20000 lbs	20000 lbs	20000 lbs	20000 lbs
	Rear axles maximum weight	44000 lbs	44000 lbs	44000 lbs	44000 lbs
	Unladen vehicle weight <sup>5</sup>	17935 lbs	17959 lbs	18047 lbs	18245 lbs
	Front axle unladen weight	10291 lbs	10302 lbs	10333 lbs	10460 lbs
	Rear axles unladen weight	7644 lbs	7657 lbs	7714 lbs	7785 lbs

# Dimension shown is for steer wheels, add approximately 2.5" for alloy wheels.  
 ## Dimension shown is for steer wheels, add approximately 2.65" for alloy wheels.  
<sup>5</sup> Alloy wheels reduce unladen weight by 695 lbs (front axle by 68 lbs, rear axles by 627 lbs).

## ProView 6x4 - Dual Control/LHS

DIESEL

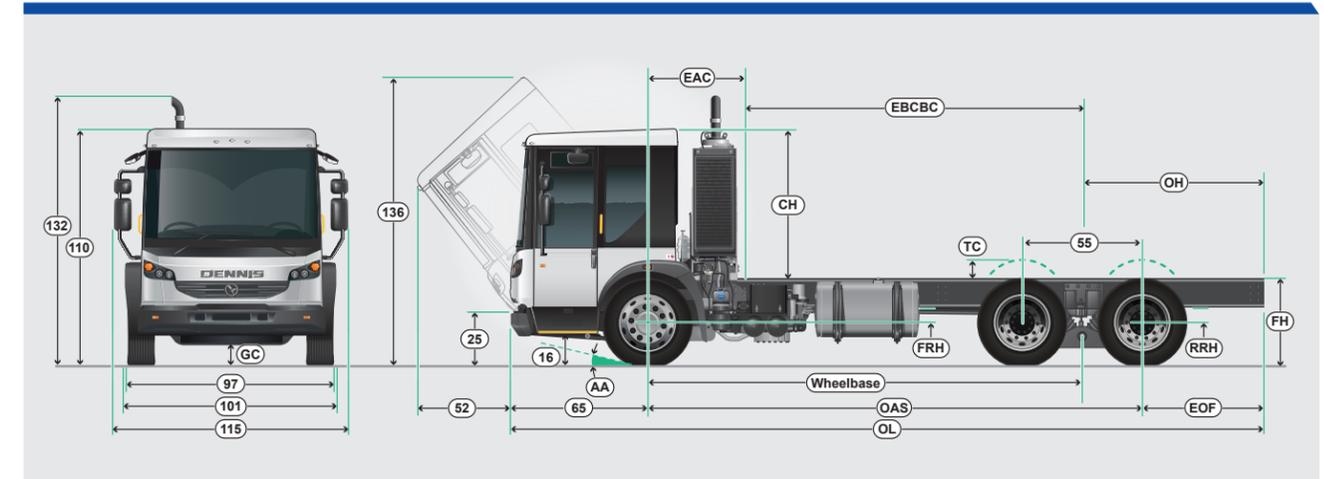

### Seating position options



### Wheel Plan

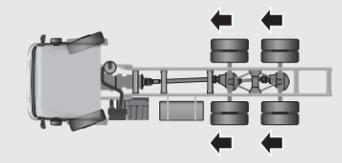

Wheelbase		181"	193"	205"	230"
OAS	Outer axle spread	208"	220"	232"	257"
OL	Overall length	333"	345"	357"	382"
EAC	Effective axle 1 to back of cab	43"	43"	43"	43"
EBBC	Effective bumper to back of cab	108"	108"	108"	108"
EBCBC	Effective back of cab to bogie centre	138"	150"	162"	187"
OH	Frame overhang from bogie centre	86"	86"	86"	86"
EOF	End of frame from rear axle	59"	59"	59"	59"
AA	Approach angle	14.5 degrees	14.5 degrees	14.5 degrees	14.5 degrees
GC	Ground clearance	9"	9"	9"	9"
FH	Chassis frame height	42"	42"	42"	42"
TC	Tire clearance (minimum)	10"	10"	10"	10"
CH	Cab height from frame	69.5"	69.5"	69.5"	69.5"
FRH	Front ride height	7"	7"	7"	7"
RRH	Rear ride height	7"	7"	7"	7"
TC W-W	Turning circle (wall to wall), ft #	64.7'	68.2'	72.8'	78.7'
TC C-C	Turning circle (curb to curb), ft ##	58.7'	62.1'	66.7'	72.7'
GVWR	Maximum plated vehicle weight	61700 lbs	61700 lbs	61700 lbs	61700 lbs
	Front axle maximum weight	20000 lbs	20000 lbs	20000 lbs	20000 lbs
	Rear axles maximum weight	44000 lbs	44000 lbs	44000 lbs	44000 lbs
	Unladen vehicle weight <sup>5</sup>	18535 lbs	18559 lbs	18647 lbs	18845 lbs
	Front axle unladen weight	10241 lbs	10252 lbs	10283 lbs	10410 lbs
	Rear axles unladen weight	8294 lbs	8307 lbs	8364 lbs	8435 lbs

# Dimension shown is for steer wheels, add approximately 2.5" for alloy wheels.  
 ## Dimension shown is for steer wheels, add approximately 2.65" for alloy wheels.  
<sup>5</sup> Alloy wheels reduce unladen weight by 695 lbs (front axle by 68 lbs, rear axles by 627 lbs).

Designed better  
to perform better

Dennis Eagle Inc  
104 G Pinnacle Way, Summerville  
South Carolina, SC 29483

T: +1 843 879 5026  
E: sales@dennis-eagle.com

[www.dennis-eagle.com](http://www.dennis-eagle.com)

